

RHIN-

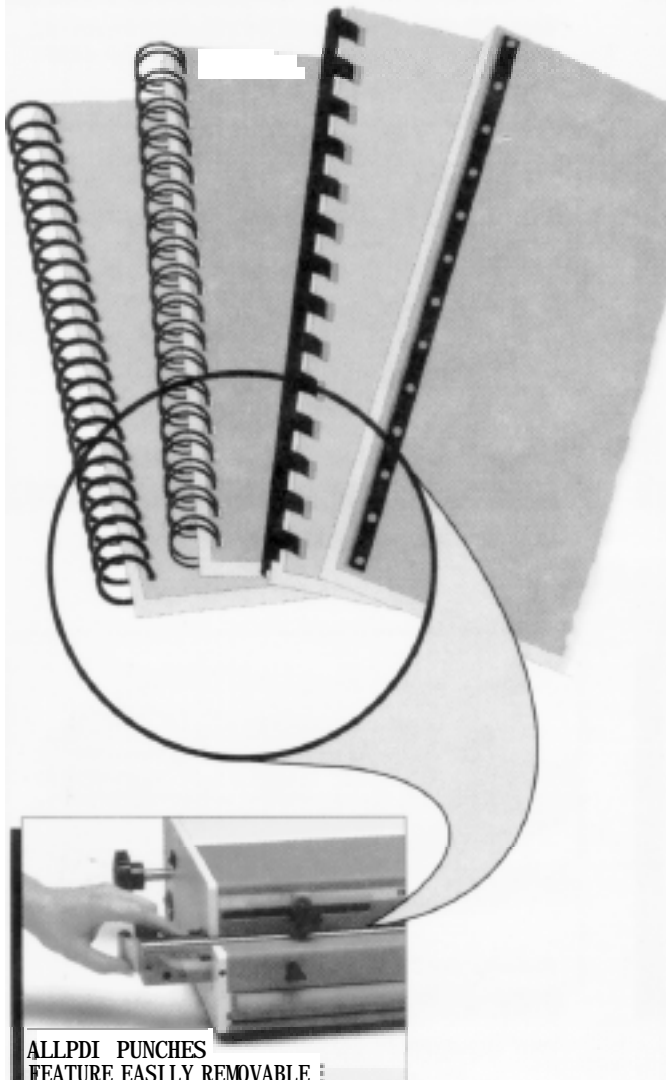

-TUFF



# INSTRUCTION BOOK FOR THE **OD 3500** AND BINDING MODULES



OD 3500 COMBO BINDING STATION WITH  
WIRE CLOSER AND COIL INSERTER



OD 3500 COMBO BINDING STATION WITH  
COMB OPENER AND COIL INSERTER



ALL PDI PUNCHES  
FEATURE EASILY REMOVABLE :

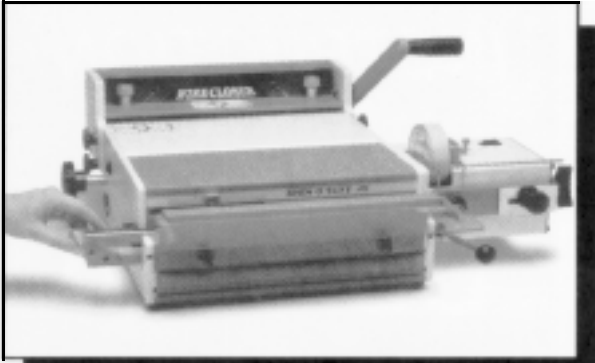

**THE OD 4000 PUNCH WITH OD 4300 PLASTIC COIL INSERTER MODULE AND THE OD 4200 WIRE CLOSER MODULE**

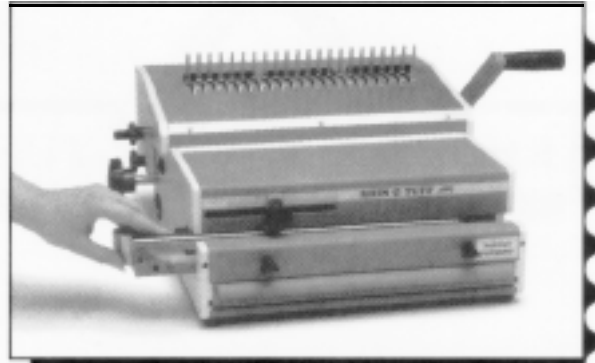

**THE OD 4000 PUNCH WITH OD 4300 PLASTIC COIL INSERTER MODULE AND THE OD 4400 COMB OPENER MODULE**

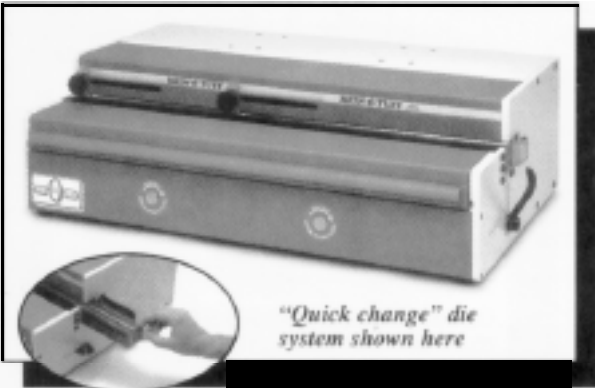

*"Quick change" die system shown here*

**THE HD 7500 24 INCH HEAVY DUTY PUNCH**

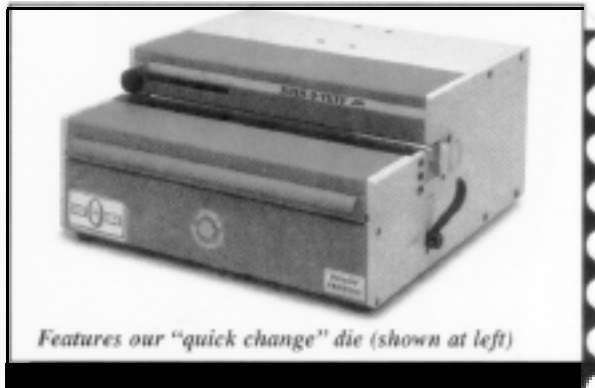

*Features our "quick change" die (shown at left)*

**THE HD 7000 14 INCH HEAVY DUTY PUNCH**

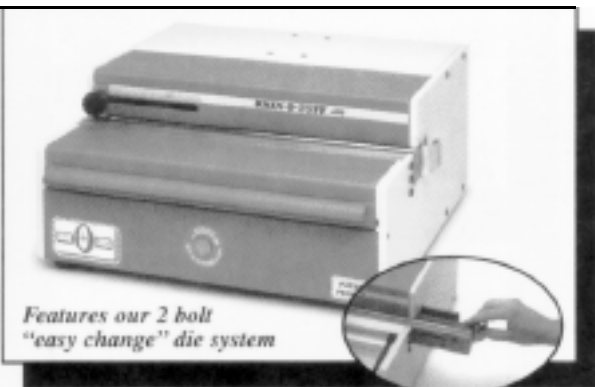

*Features our 2 bolt "easy change" die system*

**THE HD 6500 14 INCH HEAVY DUTY PUNCH**

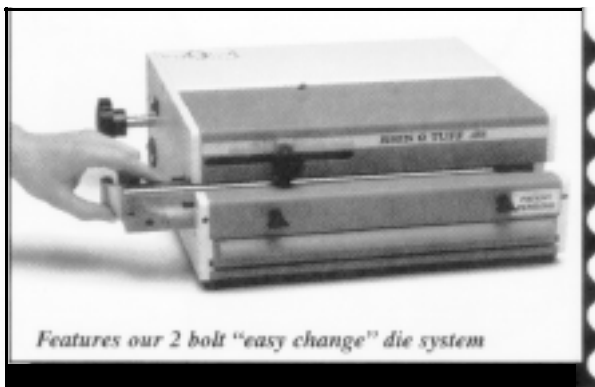

*Features our 2 bolt "easy change" die system*

**THE OD 4000 1 1/2 INCH PUNCH**

## Table of Contents

### Optional OD 3500 Combo Binding Station, Modules & Accessories

Topic	Page Number
Combo Binding Station & Modules	3&4
1) Attaching Coil Inserter module Setup Instructions	5
a) Determine the correct coil size	6
b) Determine the correct size mandrel	6
c) Installing the mandrel on the machine	6
d) Adjusting the Mandrel bracket	6
e) Adjusting the paper stop	7
f) Adjusting the front table / lexan guide	7
g) Forward / off / reverse switch	8
h) Inserting a coil	8
i) Drive wheel stop screw	9
j) Cutting a coil	9
2) Attaching Wire Closer module Setup Instructions	13
a) Determine the correct wire size	14
b) Inserting the wire into the book	14
c) Setting the closing bar height	15
d) Closing the book	15
3) Attaching Comb Opener module Setup Instructions	17
a) Determine the correct comb size	18
b) Placing the comb onto the rake	18
c) Setting the comb opener stop	18
d) Placing the book onto the comb	19
e) Margin settings	19
Setup Illustrations	
Diagram 1 Coil Inserter	5
Diagram 2a Coil Inserter	7
Diagram 2b Coil Inserter	7
Diagram 2c Coil Inserter	8
Diagram 2d Coil Inserter	9
Diagram 2e Coil Inserter	10
Diagram 2f Coil Inserter	10

<b>Topic</b>	<b>Page Number</b>
<b>Diagram 3</b> Wire Closer	<b>13</b>
Diagram 4a Wire Closer	<b>14</b>
Diagram 4b Wire Closer	<b>15</b>
Diagram 4c Wire Closer	<b>16</b>
Diagram 4d Wire Closer	<b>16</b>
Diagram 5 Comb Opener	<b>17</b>
Diagram 6 Comb Opener	<b>19</b>
Troubleshooting Coil Inserter Module	<b>11</b>
Electrical schematic Coil Inserter Module	<b>12</b>

### **Combo** Binding Station

The Combo Binding Station is a base unit that supports three different binding modules. Each module attaches in a matter of minutes. The attachment procedure will be located in the module instructional section of this manual.

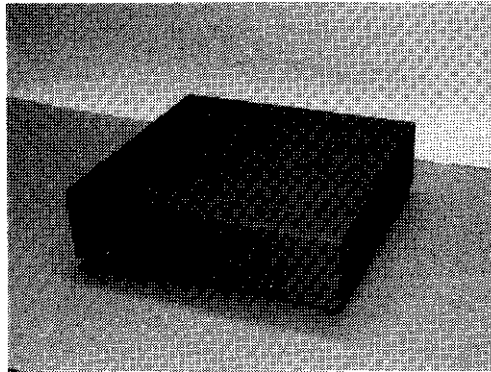

### **Coil Inserter**

The Plastic Coil Inserter will bind books up to **1-1/8"** (26.6mm) thick using coil diameter up to **1-1/4"** (30mm) The unit attaches to the right side of the Combo Binding Station or the OD 4000 Punch using two wing nuts for easy installation.

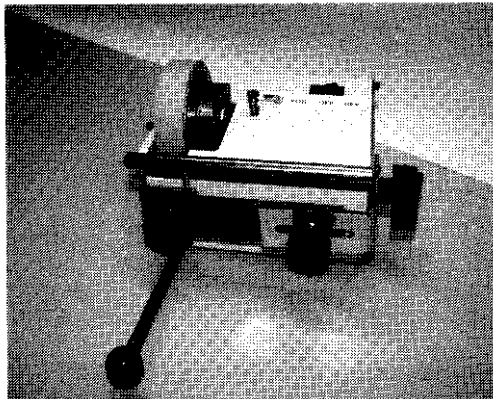

### **Wire closer**

The wire closer is capable of binding books up to  $1\frac{1}{8}$ " (28.6mm) thick. It uses wire sizes from 3/16 to 1 -1/4". It has an adjustable closing bar for the different size wires. Each end can be adjusted independently to obtain a perfect close. The unit attaches to the rear of the Combo Binding Station or the OD 4000 Punch using four knobs.

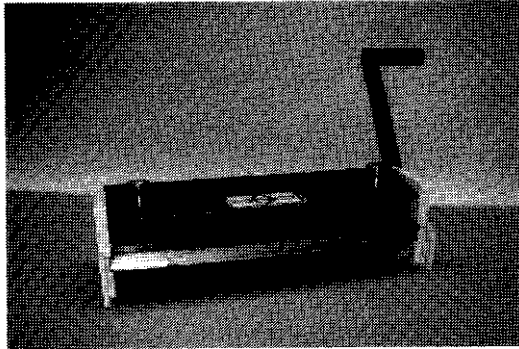

### **Comb opener**

The comb opener will bind books up to 2" (51 mm) thick. The opener has an adjustable ring opener control for exact book placement. The unit attaches to the rear of the Combo Binding Station or the OD 4000 Punch using four knobs.



All of the above modules can be ordered when ordering the Combo Binding Station or individual units can be ordered at a latter date. Each unit can be installed in a matter of minutes. The coil inserter can be attached and kept on the Combo Binding Station or the OD 4000 Punch permanently. If the Wire closer module is installed on the Combo Binding Station or the OD 4000 Punch and the Comb opener module is required: the wire closer will have to be removed so that the comb opener can be installed. The opposite is also true. It only takes a few minutes to detach any one of the modules to install any other one.

# Coil Inserter Module

## 1) Installation Instructions: Diagram 1

Procedure to attach the coil inserter onto the Combo Binding Station or the OD 4000 Punch.

- + Align the two threaded studs (1) that protrude from the coil inserter option into the two holes located on the right side of the Combo Binding Station or OD 4000 Punch.
- + Use the two wing nuts provided with the coil inserter to attach the unit. Hand tighten the two wing nuts.
- + Attach the paper stop bracket (2) to the right side of the Combo Binding Station or OD 4000 Punch using the two black thumb knobs (3) provided.
- + Use two black thumb knobs (4) to attach the book table / lexan coil guide to the Combo Binding Station or OD 4000 Punch. (The book table / lexan guide has been removed to view the diagram, see diagram 10b to view the book table / lexan guide in position)
- + Plug one end of the power cord into the back of the coil inserter option and the other end into the wall outlet.

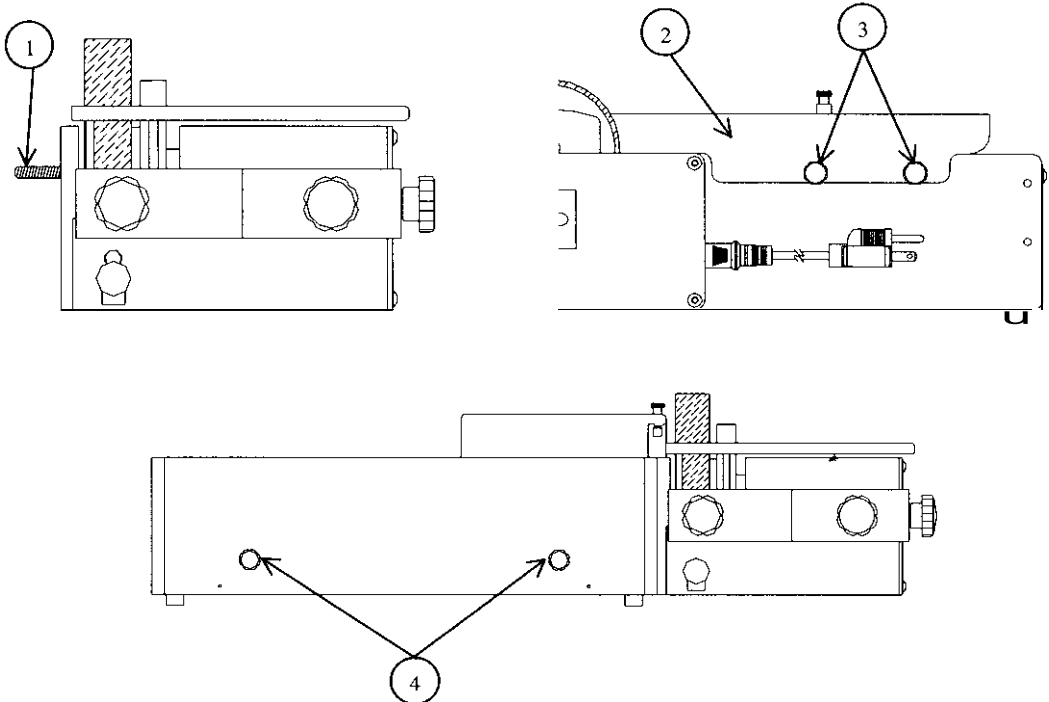

Diagram 1

Setup Instructions: Diagram 2a, 2b, 2c, 2d & 2e

a) Determine the correct coil size.

Use a coil that is at least 3/32 (2.5mm) larger than the book thickness for coil sizes up to 3/4" (20mm). After 3/4", use a coil size of at least 1/8" over the book size. The larger the coil compared to the book, inserting will become much easier.

b) Determine the correct size mandrel.

There are a total of nine mandrels, which are used for coil sizes 3/16" (5mm) up to 1-1/4" (30mm). Use the below table to choose the correct mandrel size to coil size.

<u>Mandrel size</u>	<u>Inch</u>	<u>Coil size mm</u>
3/16"	3/16" to 1/4"	(5mm-6mm)
1/4"	5/16"	(7mm-8mm)
5/16"	3/8"	(9mm-10mm)
3/8"	7/16" to 1/2"	(11mm-12mm)
1/2"	9/16"	(13mm-16mm)
5/8"	3/4"	(17mm-19mm)
3/4"	7/8"	(20mm-23mm)
7/8"	1"	(24mm-27mm)
1"	1-1/8" to 1-1/4"	(28mm-30mm)

c) Installing the mandrel on the machine

- + Place the mandrel (1) into the mandrel holder bracket (2) making sure the beveled edge of the mandrel is facing the right side of the machine. Both guide pins located on the mandrel need to line up with both slots on the mandrel bracket. Use the black knob (3) to tighten the mandrel in place.
- + Adjust the height of the mandrel so the center of the mandrel is the same height as the center of the book.

d) Adjusting the mandrel bracket,

- + The mandrel assembly-adjustment knob (4) is located on the right side of the coil inserter, Move the mandrel bracket assembly towards the drive wheel for small mandrels and away from the drive wheel for the larger mandrels.
- + The mandrel holder bracket-adjustment knob (5) can be adjusted to the left or the right so the leading edge of the coil lines up with the first hole of the book.

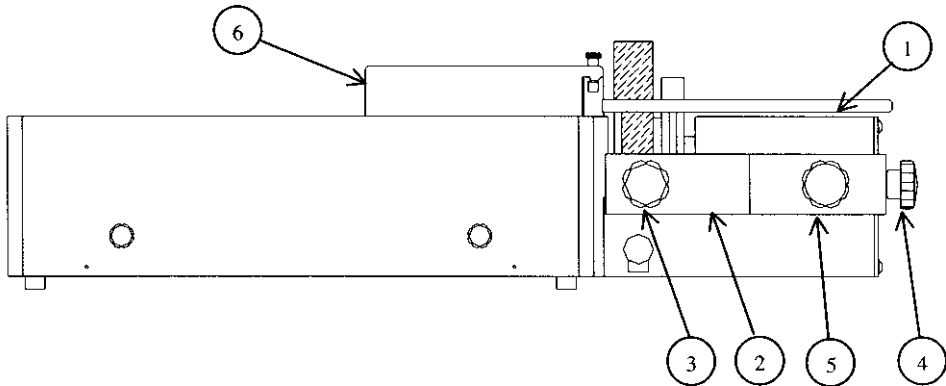

Diagram 2a

a) Adjusting the paper stop.

Place the book on top of the Combo Binding Station or the OD 4000 Punch with the right side of the book against the paper stop bracket. Adjust the paper stop (6) so the holes of the book hang over the edge of the Combo Binding Station or OD 4000 Punch. The **holes should hang over the edge just enough for the coil to clear the edge of the Combo Binding Station or the OD 4000 Punch**. Tighten the knob located on the paper stop bracket. It may be necessary to fine-tune this after a few books are bound for exact placement.

f) Adjusting the front table / lexan guide

The **front table/ lexan guide (7,a & 7b)** has two purposes. (FIRST): When the lexan is in the closed position, rotated on top of the coil (7a), it will assist the coil to insert smoothly into the book. You should **use** the lexan guide with all books regardless of thickness. (SECOND): With the lexan guide (plastic) in the open position, **rotated** away from the machine, it acts as a support table (7b) for large books. For book's over 9/16" thick, it may be necessary at times to start the coil into the book, then split the book in half using the table to support one half of the book, then finish the inserting of the coil. This method improves productivity.

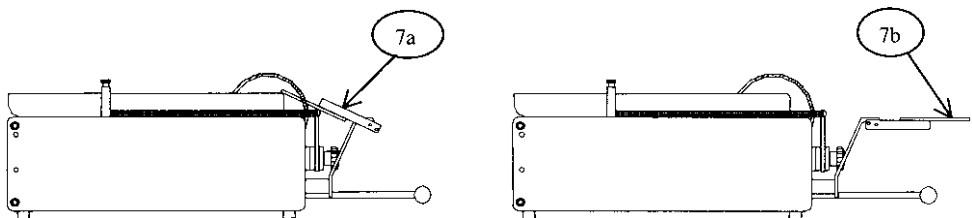

Diagram 2b

g) Forward /off / reverse switch.

The forward / off / reverse (8) switch has three positions. The center position of this switch is the off position and should be placed in this position when not using the machine. Press the left side (forward) of the switch and the coil will rotate into the book. Press the right side (reverse) of the switch and the coil will exit the book. The reverse feature allows the coil to be removed from the book. Sometimes this will be necessary when the leading edge of the coil misses a hole of a single sheet.

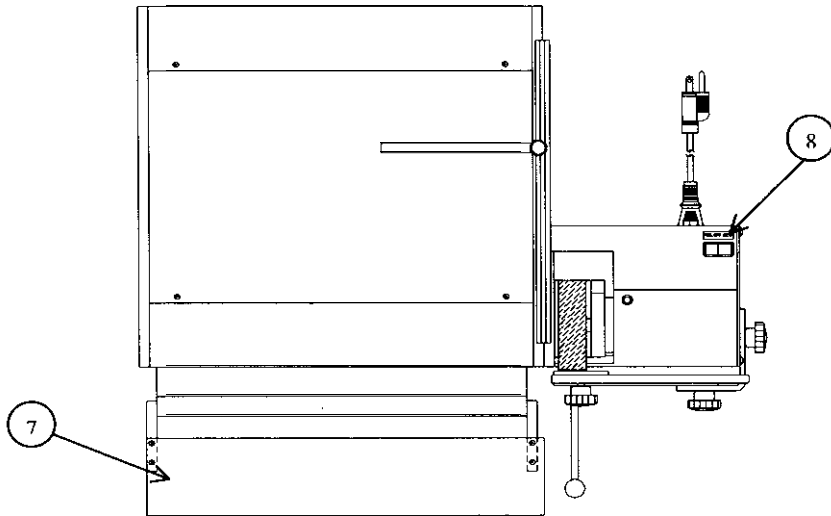

Diagram 2c

h) Inserting a coil

Place the coil on the mandrel by sliding the open end of the coil onto the beveled end of the mandrel. Turn the coil so it threads onto the mandrel post (9) and is in front of the drive wheel by one coil. Make sure the forward / reverse switch is in the forward position. Pull the motor handle (10) down to start the motor and engage the drive wheel (11) to the coil. Rotate the coil so it comes close to the edge of the book, but not past the book. With your right hand, hold the leading edge of the coil and thread it through the first two holes of the book. This helps align the holes of the book. Rotate the lexan guide on top of the coil. Pull the handle down gently at first making sure the coil is rotating into the book without missing

holes in the sheets or covers. Continue until the coil is past the left side of the book by about one or two coils.

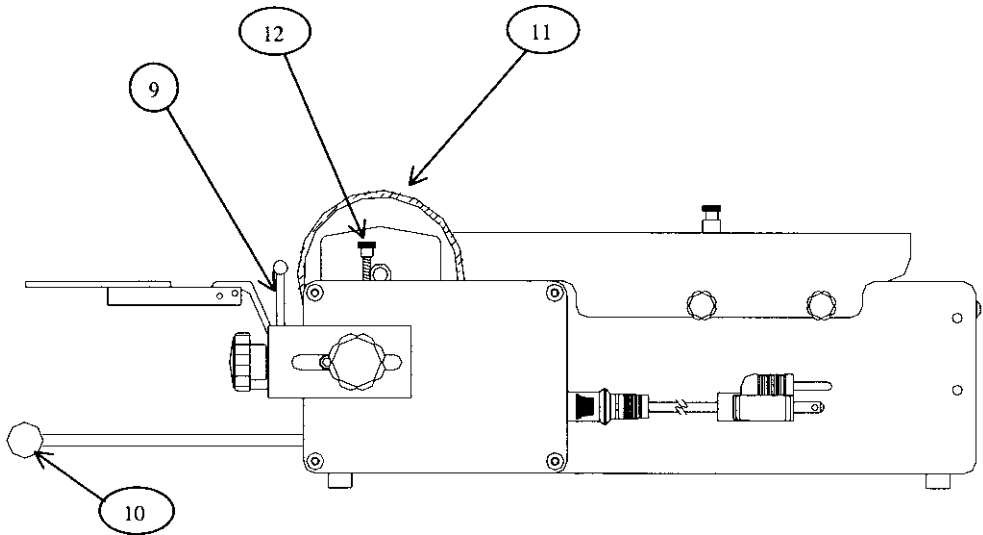

Diagram 2d

i) Drive wheel stop screw.

The drive wheel **stop screw (12)** will prevent the wheel from pressing too hard on the mandrel. It is very important not to have too much pressure on the mandrel when inserting the larger coils. If the leading edge of the coil stops on a misaligned sheet, the coil wants to tie itself into a knot between the book and the end of the mandrel. Setting the stop screw will prevent this from happening most of the time. To set the stop screw, turn it clockwise to push the wheel away from the mandrel. Load the coil onto the mandrel and turn the stop screw counter clockwise while holding down on the motor **handle (10)** until **the drive wheel touches** the coil. Try a few **books and readjust if necessary.**

**If the mandrel bracket is adjusted after the stop screw has been adjusted, it will be necessary to readjust the stop screw.**

j) Cutting a coil

There are special cutter crimper pliers (ordered separately) that are used to terminate the ends of the coil. After the coil is cut, the sharp end of the coil will tuck itself under the inside of the coil opening. To use the cutter, make sure the red dot (13) is facing up. Place the cutter on the

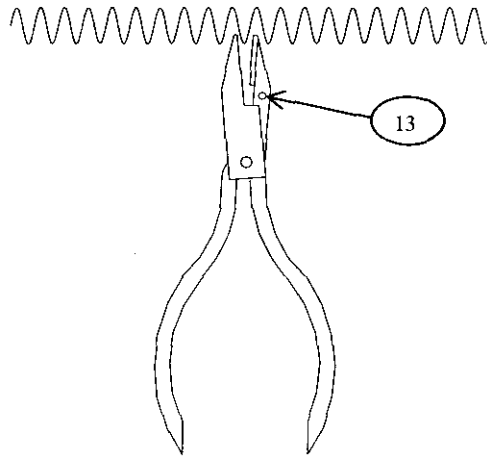

**Diagram 2e**

**edge** of the right hand side of the book. Open the cutter enough so that the end of the cutter enters the coil by about a 1/4". Make sure the cutter **is level with the book before you cut**. As you squeeze the cutters you may notice the coil wants to twist. You can support the coil with your fingers as you cut to help stabilize the coil. Turn the book over and repeat these steps on the opposite end of the book. Always make sure to close crimping cutters completely.

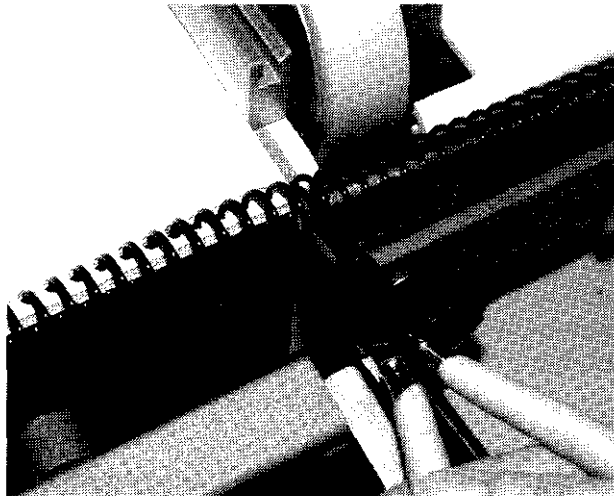

**Diagram 2f**

# Wire Closer Module

## 2) Installation Instructions: Diagram 3

**Procedure** to attach the wire closer onto the Combo Binding Station or the OD 4000 Punch.

- ◆ Place the closer module on the backside of the Combo Binding Station or the OD 4000 Punch so the closer adjustment knobs are facing the front of the Combo Binding Station or the OD 4000 Punch and are pointing up.
- ◆ Attach the closer with four black knobs (1) provided with the closer module. Use two knobs on each side to secure the unit in position.
- ◆ Attach the closing handle (2) either to the right or left side of the closer using the screw (3) provided with the closing module. Use the allen key provided with the closing module to secure the handle in place.
- ◆ The book table / lexan guide & the top paper stop assembly should be removed while using the wire closing module. (Combo Binding Station or OD 4000 Punch fitted with **Coil Inserter Module Only**)

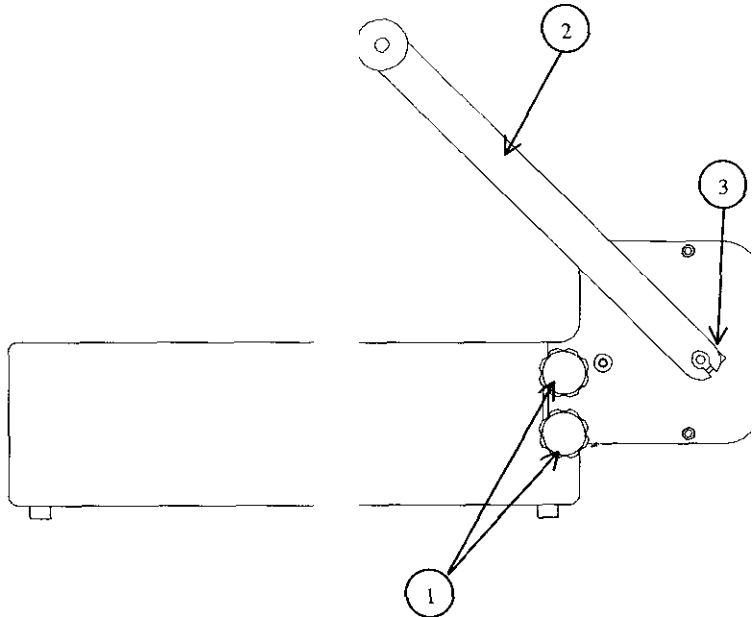

**Diagram 3**

# Coil Inserter Module Electrical Schematic (120 volt AC)

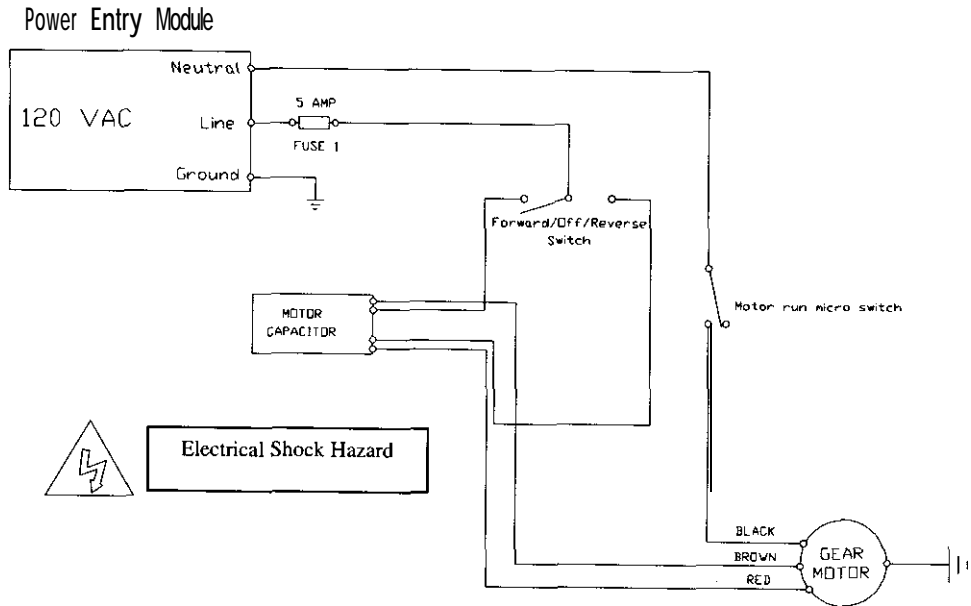

NOTE: The motor is protected by a thermal overload located in the motor. It will reset automatically after the motor cools.

This product has earned the UL Listing Mark and the UL Listing Mark for Canada. EI 79574

**The CI 3000** has been tested with a duty cycle of 4 seconds on, 15 seconds off with a rest period of 2 minutes after 30 seconds of run time.

The CI 3000 is also **know as the Coil Inserter Module OD 4300.**

## Wire Closer Module

### 2) Installation Instructions: Diagram 3

Procedure to attach the wire closer onto the Combo Binding Station or the OD 4000 Punch.

- ◆ Place the closer module on the backside of the Combo Binding Station or the OD 4000 Punch so the closer adjustment knobs are facing the front of the Combo Binding Station or the OD 4000 Punch and are pointing up.
- ◆ Attach the closer with four black knobs (1) provided with the closer module. Use two knobs on each side to secure the unit in position.
- ◆ Attach the closing handle (2) either to the right or left side of the closer using the screw (3) provided with the closing module. Use the allen key provided with the closing module to secure the handle in place.
- ◆ The book table / lexan guide & the top paper stop assembly should be removed while using the wire closing module. (Combo Binding Station or OD 4000 Punch fitted with Coil Inserter Module Only)

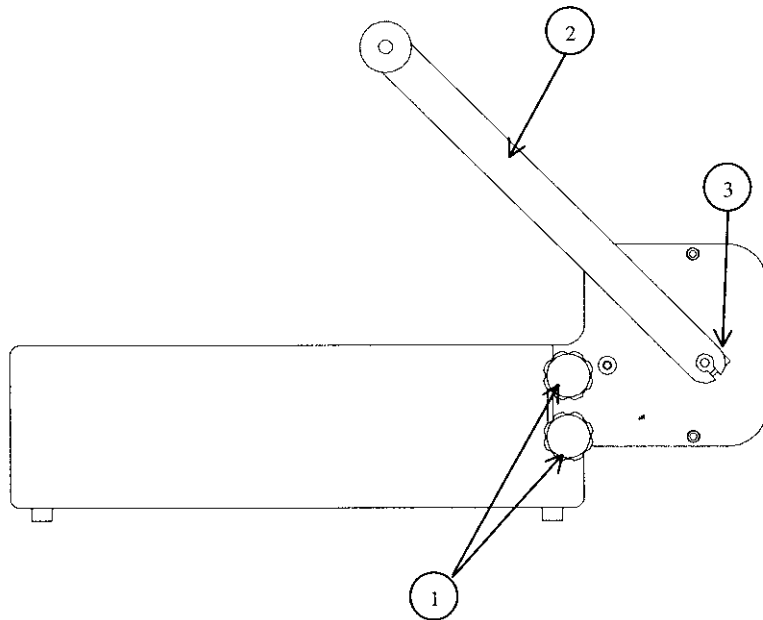

Diagram 3

Setup Instructions: Diagram 4a, 4b, 4c & 4d

a) Determine the correct wire size.

Use the table below to determine the correct wire size for the book thickness. You can insert more sheets into the wire, but it may affect the appearance of your book. Covers are not included with the number of sheets column.

Wire Diameter		Book Thickness		Number of sheets	
Inch	mm	Inch	mm	20lb	80gsm
3/16	4.8	1/8	3.2	30	
1/4	6.4	3/16	4.8	45	
5/16	7.9	1/4	6.4	65	
3/8	9.5	5/16	7.9	80	
7/16	11.1	3/8	9.5	95	
1/2	12.7	7/16	11.1	110	
9/16	14.3	1/2	12.7	125	
5/8	15.9	9/16	14.3	140	
3/4	19	5/8	15.9	160	
7/8	22.2	3/4	19	190	
1	25.4	7/8	22.2	220	
1-1/4	31.8	1-1/8	28.6	285	

b) inserting the wire into the book.

First, prep the book by removing the back cover and place it on top of the front cover. This will position the binding edge of the wire at the inside cover at the back of the book. Place the book on the edge of a table so the holes overhang the table a slight amount. Make sure the covers are facing down and under the main body of text when placing the book on the table. Insert the narrow loop into the holes of the book with a slight rotating action. Start with the left side and slide your finger along the wire to thread it into the remaining holes.

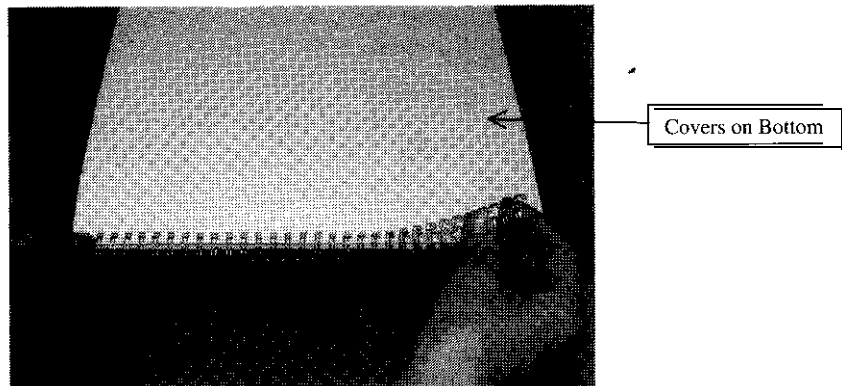

Diagram 4a

c) Setting the closing bar height

The closing bar is adjustable on each end allowing the operator to achieve a perfect close at each end of the book. Pull the handle on the closer all the way down and adjust both **knobs (3)** so the **top edge (4)** of the closing bar lines up with the line (5) next to the wire size you want to close.

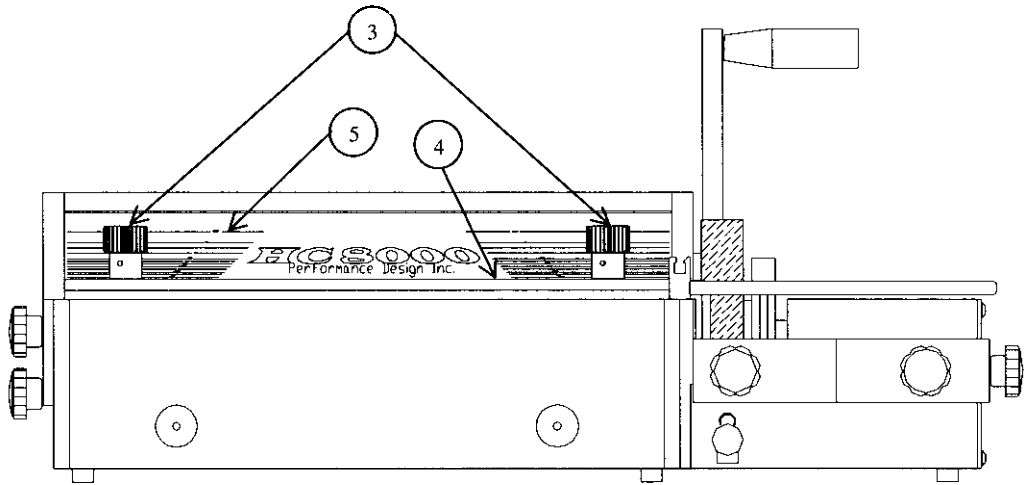

Diagram 4b

d) Closing the book.

With the handle in the full upright position place the book so the open end of the wire is firmly pressed against the back plate (6) inside the closing machine (see diagram 4c on page 16). The narrow loop (7) should be on the top of the book while pushing the book against the back plate. Hold the book as you pull the handle (8) down. Inspect the close and readjust the closing bar if necessary. When the wire is closed properly, the narrow loop overlaps the wide loop by about **1/16"** along the entire length of the book. An indication that the wire is not closed tight enough is when the covers or sheets fall out of the book.

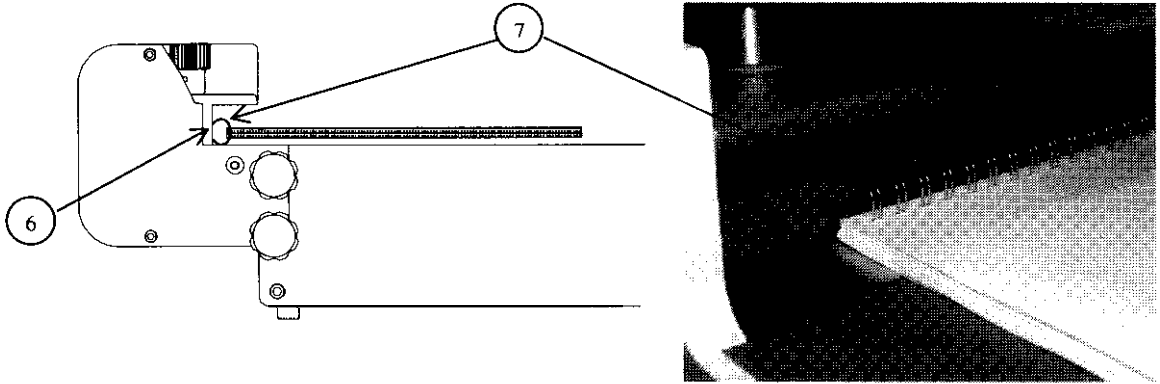

Diagram 4c

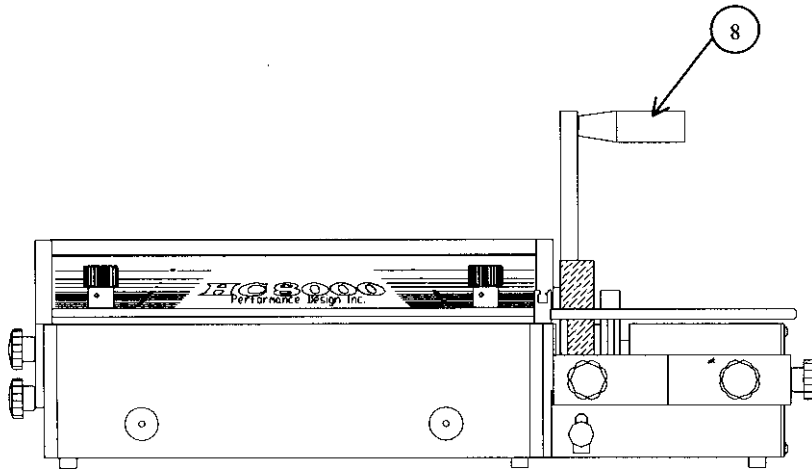

Diagram 4d

# Comb Opener Module

## 3) Installation Instructions: Diagram 5

Procedure for attaching the comb opener onto the Combo Binding Station or OD 4000 Punch.

- ◆ Place the comb opener module on the backside of the Combo Binding Station or OD 4000 Punch so the narrow section of the comb opener is facing the front.
- ◆ Attach the comb opener with four black knobs (1) provided with the comb opener module. Use two knobs on each side to secure the unit in position.
- ◆ Attach the comb **opener handle (2)** either to the left or right side of the comb opener using the screw (3) provided with the comb opener module. Use the allen key provided with the comb opener module to secure the handle in place.

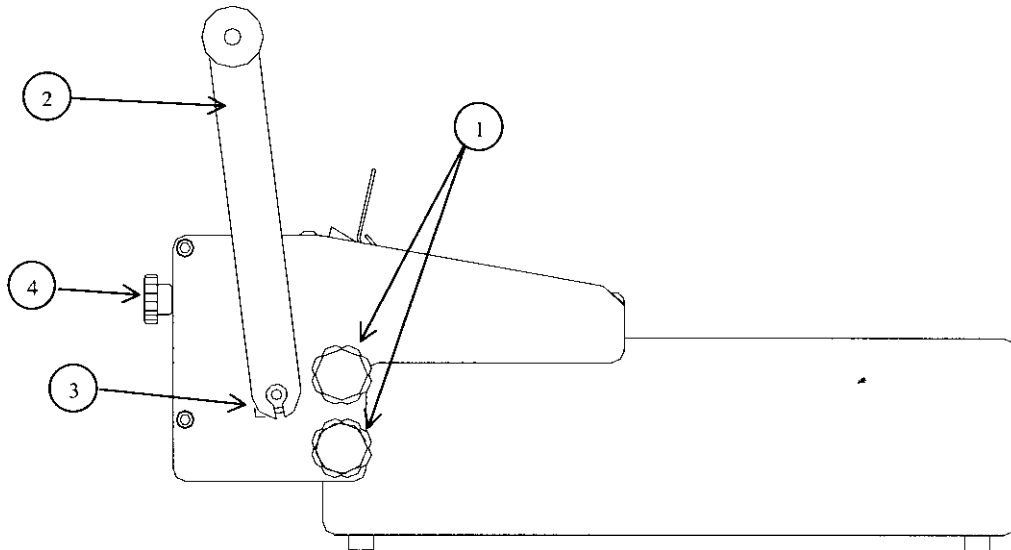

Diagram 5

a) Determine the correct comb size.

Use the table below to determine the correct comb size for the book thickness. You can insert more sheets into the comb, but it may affect the appearance of your book. Covers are not included with the number of sheets column.

<b>Comb Diameter</b>		<b>Book Thickness</b>		<b>Number of sheets</b>	
Inch	mm	Inch	mm	20lb	80gsm
3/16	4.8	1/8	3.2	30	
1/4	6.4	3/16	4.8	45	
5/16	7.9	1/4	6.4	65	
3/8	9.5	5/16	7.9	80	
7/16	11.1	3/8	9.5	95	
1/2	12.7	7/16	11.1	110	
9/16	14.3	1/2	12.7	125	
5/8	15.9	9/16	14.3	140	
3/4	19	5/8	15.9	160	
7/8	22.2	3/4	19	190	
1	25.4	7/8	22.2	220	
1-1/8	28.6	1	25.4	250	
1-1/4	31.8	1-3/32	27.8	275	
1-1/2	38.1	1-3/16	30.1	300	
1-3/4	44.5	1-7/16	36.5	360	
2	50.8	1-11/16	42.8	425	

b) Placing the comb onto the rake. **Diagram 6**

Place the comb onto the rake with the fingers of the comb facing the front of the machine. The solid section of the comb will be facing the rear of the machine. Make sure the points of the fingers are facing up. Pull the opener handle down to open the fingers of the comb.

c) Setting the comb opener stop. **Diagram 5**

The comb opener **stop knob (4)** is located on the rear of the comb opener. Set the comb opener stop by turning the knob counter clockwise so the comb opens far enough to place a book on the fingers of the comb, but not to far so the comb is lying flat with no room for the book.